

Dyna Miniature Series Coil

DC1-2 / DC1-3 Dual Output

DC3-2 / DC3-3 Single Output

3 Ohm Primary

Thank you for your purchase of the new Dynatek Miniature Series coil. Outstanding features of this innovative design include:

- ▶ Advanced magnetic core technology. Delivers exceptionally high output in one of the smallest packages available. Great for custom bikes, where the coil must be hidden without sacrificing performance.
- ▶ Spark plug style tower design. Assures a positive locking, watertight seal when used with standard spark plug boots.
- ▶ Works with all types and sizes of spark plug wires. Low profile tower easily accommodates even the fattest spark plug wires and boots.
- ▶ Oval mounting ears accept a wide range of mounting bolt spacings. Ears are reinforced to prevent damage from over-tightening mounting bolts.
- ▶ Core is completely encapsulated to prevent corrosion and loss of performance.
- ▶ Rugged, yet light-weight design.

Installation Notes

This coil is designed for use with the Dyna 2000 & 3000 series ignitions, factory installed electronic ignitions, or other aftermarket ignitions that employ dwell control. They should not be used with the Dyna-S, Dyna-III, or other early generation ignition kits.

The mounting ears are slotted to accommodate most of the popular bolt spacings. However, the ears are thicker than most factory coils and may require longer bolts for installation. Some installations may require additional modification, or fabrication of mounting brackets.

This coil is polarity sensitive. Improper connection will not damage the coil, but will substantially reduce performance. See illustration for proper connection.

Use of dielectric grease or other waterproofing agents should not be used on the high voltage tower, since contamination may cause leakage of high voltage and loss of performance. The primary terminals may be lightly coated with grease for corrosion protection.

Wiring

Make a sketch of how the existing coils are connected. This will be helpful if troubleshooting is required.

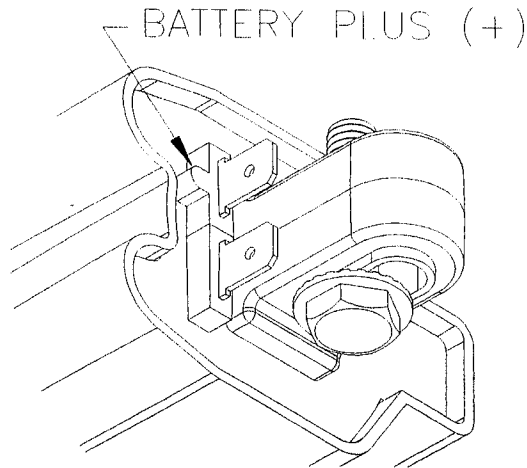

Remove all wires from the coils. Turn on the key and use a test light to identify the wires that are connected to BATTERY(+). Connect these to the (+) terminals of the new coils. The coil (+) terminal is identified by the small bump molded next to it.

Some installations may require one or both of the factory installed connectors to be cut off.

If the factory coil has wires for the primary connection, these should be cut about 2" from the coil. This will provide enough wire to reattach the old coil if required for troubleshooting. Crimp connectors are supplied with this kit to finish the wires.

Specifications

Primary Resistance: 3 ohms
Secondary Resistance: 11.5K ohms
Secondary Available Voltage (unloaded): 35 kV
Secondary Available Voltage (loaded): 28 kV*
Overall Dimensions: 4.2" x 2.3" x 1.6"
Mounting Centers: 2.9" min; 3.5" max

Primary Inductance: 14 mH
Secondary Inductance: 29 H
Spark Energy: 50 mJ
Secondary Current: 60 mA
Approx. Weight: 9.8 oz

* Measured in accordance with Society of Automotive Engineers recommended practice - Ignition System Measurements Procedure SAE J973a (50pF load).